

2022-08-22 FVCA Regular Board of Directors Meeting

Monday, August 22, 2022 7:08 PM

Agenda

Call to Order

Approval of Minutes - Deal

Treasurer Report - Branch

Advisory Committee Reports

Community Facilities - Hill

Parks and Maintenance - Hill

TIRZ 17 - Dunson

Memorial Super Neighborhood - Bonnin

Social - Rosca

Website - Bentaleef

Capital Improvement - Zoch

New Business

Discuss the fence proposals for the pool property; select and vote on approving one

Meeting Adjourn

Attendees

Alexander Rosca, Lindsay Deal, Kyle Hill, Fletcher Dunson, Dan Zoch, Michael Ferrier

Call to Order

7:16 PM - Fonn Villas Swim Facilities

Approval of Minutes - Deal

May minutes posted on the website

Rosca motion to **approve minutes as posted**, Zoch seconded, **approved**

Treasurer Report - Branch

Attach Natalia's report

Maintenance

Revenue \$2K less than budgeted due to 2 outstanding balances

Action: Branch to escalate collections of outstanding balances to legal counsel

Expenses: \$4K less than budgeted due to lower legal and architectural review costs

Pool

Revenue \$2.5K more than budgeted, concessions brought in \$3K, sponsorships brought in \$2K, approximately 50 external members

Expenses: \$10K under budget on expenses, swim team \$6K over budget, pool maintenance \$6K under budget (may be due to timing for Sweetwater billing), pool repairs \$1.5 under budget, landscaping under budget

\$230K in reserves

\$40K in operating budget, loosely earmarked for a new fence

Architectural Committee Report - Aburubia

Q2 Report Delivered

Significant decrease in requests from Q1

Change to the finish on the Vindon house, still within guidelines but may require a change submitted 12627 Kingsride initially on a renovation permit for an expansion, 40% of framing demolished and then decided to tear it down to the foundation, may require a major construction permit

Action: Aburubia to request a major construction permit

Advisory Committee Reports

Community Facilities - Hill

Need new flags for lap pool for \$500

Action: Marshall to order new flags for end of September delivery

Parks and Maintenance - Hill

City fixed the tennis court screen

City can't fix the lights - it's complicated electrically

TIRZ 17 - Dunson

Crème de la Crème - multi-family midrise no known build date

Next to Microsoft - new office to start in next few weeks

Strip center with Nori - 1-story high-end retail

Existing retail with Quiznos - no change

Memorial Drive expansion project to be completed by end of September

Next phase from Tallowood to Gessner is being redesigned

Memorial Super Neighborhood - Bonnin

Next meeting next Monday

Social - Deal

No report

Website - Bentaleef

No report

Capital Improvement - Zoch

Proposing a project for two or three phases

Phase 1 - next 60 days, irrigation and tree trimming, fence

Long-term electrician to review existing electrical issues

Dunson to bid to re-asphalt parking lot, existing demo and hauled off at no cost and repaved \$11K, will come back for board approval

Phase 2 - Painting building, replacing the window and restroom doors, repair any rotted wood, replacing concession, paint and repair restrooms, power wash repair and paint the pavilion, epoxy texture floor, rework the electric, patch any roof issues

Action: Capital Improvement Committee to distribute scope to several general contractors to bid, hope to award in December

Phase 3 - open for playground replacement, decking, pool resurfacing and other options

Pool decking requires piping and electrical and requires \$150K in reserves

Action: Aburubia to get a bid to estimate to hold for reserves

New Business

Discuss the fence proposals for the pool property; select and vote on approving one

Three bids for replacing fence existing footprint notched for existing trees, one sided, 8 feet tall, demo, haul-off and temporary fence

Low bid is a resident of the neighborhood, qualified fence company \$41.5K

Additional cost to trim (up to \$2K already budgeted), review and adjust sprinklers to preserve life of fencing, staining of fence

Rosca motion to **approve the \$41.5 bid with a total spend up to \$50K for additional scope items**, Hill seconded, approved

Action: Zoch to provide bids for attachment to the minutes

Meeting Adjourn

8:12 PM

lindsay.faye.deal@gmail.com

From: Alexander Rosca <alexander.rosca@gmail.com>
Sent: Friday, January 6, 2023 5:16 PM
To: Lindsay Deal
Cc: Kyle Hill; Dan Zoch; Fletcher Dunson; Andy Bonnin; Natalia Branch; Charles Sturm; Michael Ferrier
Subject: Fence bids to be attached to the August Meeting Minutes
Attachments: Superior Fence & Rail - Option 1 wood posts.pdf; Superior Fence & Rail - Option 2 steel posts.pdf; Fonn Villas Wood fence quote around pool.eml (3.19 MB); Griffin Fence_2022-07-21_Kyle.pdf; Titan Fence Fonn Villas Swim Club - Wood Fence - Revised Quote - August 20, 2022.doc; Houston Fence Proposal.pdf

Flag Status: Flagged

Lindsay,

in order to keep things simple, I collected all fence bids which I am attaching to this email. We will need to add them to the August meeting minutes when we discussed and approved the new fence.

Please let me know when you have all the unapproved meeting minutes so we can approve them via email. Also, do you have the Annual Meeting minutes from January 2022? I believe these need to be approved at the January 2023 Annual Meeting.

Thank you,
Alex

From: Ruben Zarco <ruben@griffinence.com>
Sent: Wednesday, July 13, 2022 4:30 PM
To: Fletcher Dunson
Subject: Fonn Villas Wood fence quote around pool
Attachments: 8 ft tall cap trim 2x12 base1.jpg

Hello, Mr Dunson

Thank you for giving Griffin Fence the opportunity to quote your fence project.

Customer name: Fonn Villas

Job Address: 635 Hallie Dr. Houston, Tx. 77024

Griffin Fence is pleased to Furnish and install the following fence quote.

Scope of Work:

1. Furnish and install 718 linear ft x 8 ft tall Western red cedar **double sided** picket wood fence around the perimeter of the property pool area.
2. Furnish and install (1) 4 ft wide x 8 ft tall wood gate by the pool equipment enclosure.
3. Furnish and install (1) 4 ft wide x 8 ft tall wood gate at the front right side gate entrance between wood fence and building.

Remove and haul away all the existing fence to be replaced.

Wood fence material Includes:

1"x 6" wide x 7 ft tall Cedar double sided pickets set with 1-7/8" Aluminum shank nails, 2" x 12" Pressure treated pine baseboard with a 45-degree beveled edge, 2" x 8" Cedar cap, 1' x 2" Cedar trim, 2" x 4" Pressure treated horizontal support wood rails (3) per fence panel set with 3" galvanized framing nails, Pressure treated pine 4" x 4" fence posts set 2'-6" below ground in concrete footings. Wood gates include a 1" Galvanized tubular steel gate frame with gate latch.

Job Lump Sum Price \$ 73,238

Note: All Shrubs, Vines, Tree branches would need to be cut and trimmed by others one foot away from the existing wood fence on both sides before Griffin Fence removal of the existing fence.

All electrical wires, Cables, Mosquito lines or anything attached to the existing fence on both sides would need to be removed by others before Griffin fence removal of the existing fence.

Note: Property owner is responsible for surveying the property lines and to direct the fence contractor where the fence line stakes, or property markings are located.

Note: This quote is good for (7) days due to the fluctuating price changes from our material suppliers.

If you have any questions, please feel free to contact me. Regards

Ruben Zarco
Griffin Fence

6307 Brittmoore
Houston, Tx. 77041
Tel: 713-937-6611
Cell: 708-712-3799

E-mail: ruben@griffinfence.com
www.griffinfence.com

A+ Rating with the: Better Business Bureau

Member in good standing with the American Fence Association.

Serving The Houston metropolitan area and surrounding cities. Since 1979



Griffin Fence
— Building quality fences. Since 1979 —

Attached please find a picture of the proposed double sided cedar picket wood fence.



HOUSTON FENCE COMPANY, INC
Since 1952

11851 ORMANDY ST.
HOUSTON, TEXAS 77035

PHONE (281) 499-2516
FAX (832) 539-1144

PROJECT BID

DATE: August 19, 2022
PROJECT: Cedar Wood Fence
CLIENT: Kyle Hill – 713-899-3054; kyle@westsiderealtors.com
Fonn Village: 635 Hallie Dr. Houston, TX 77024

- FENCE TYPE: Privacy, #2 or better cedar
- LINEAR FOOTAGE: 720 linear feet of fence
- HEIGHT: 8'2" Tall
- PICKETS: 1"x6"x7'
- BASEBOARD: 2"x12" beveled edge treated pine
- CAP & FACE: 2"x6" cedar cap with 1"x2" cedar face
- RAILS: 3 – 2" x4" treated pine rails, toe in nailed
- NAILS: Hot dip galvanized ring shanked nails to be used
- POSTS: 4"x4" Treated posts set 3' deep in concrete on 6' centers
- GATES: (1) 4' & (1) 5' walk gate, both gates include galvanized tubing framework, self-tapping screws on the square frame, powder coated black T-hinges, & a paddle latch accessible from both sides of the fence, but lockable from inside
- TEAR & HAUL: Included

Houston Fence will notify the "One Call" center for locating and **marking all public utilities** on and by the property. Houston Fence Co. is licensed by the State of Texas No.# B16502 and **insured/bonded through by Allied P & C Insurance Company up to \$5,000,000 liability each occurrence.**

Grand Total: \$44,269.04

Please Note: Both availability of product and price in the wood market is extremely volatile at this time. As such, pricing and availability of material will have to be confirmed at time of award to confirm if current prices are up or down and availability.

EXCLUSIONS: Unless noted above. Clearing, grading or locating and marking private underground utilities. Breaking concrete or asphalt to set fence posts, electrical grounding of fence. Permits, bonds, waivers of subrogation and naming of additional insured parties or unless specifically stated above are excluded.

APPROVAL: _____ DATE: _____
(Signature)

Grafton Moore, Sales Representative
Houston Fence Co., Inc.
832-525-3038
grafton@houstonfence.com



(P) 281.265.2881 www.houstonfence.com

WHY USE HOUSTON FENCE FOR YOUR WOOD FENCE AND GATE NEEDS

- All of our wooden gates have a galvanized 1-1/4" welded steel frame for support, use patented self-closing hinges, and hang on a hinge post set 4.0' deep in a 240# concrete footing.
 - Pedestrian gates come standard with a powder-coated paddle latch which has a pin lock on the inside & a padlock receiver on the outside.
- All of our fence posts are pressure treated & ground rated to minimize moisture absorption and are set 2' deep underground for 6' tall material, and 3' deep for 7' & 8' tall material, in concrete for long term stability. Deeper footings are available at an additional cost
- All our fences use #2 or better Western red cedar pickets. All materials are milled in North America exclusively (Houston Fence Company uses only the best quality product).
- All our fences use 3 rails and are boarded together with galvanized ring shank nails so they will not back out over time.
- If you elect to use a cap rail for your fence we ONLY use cedar (unlike our competitors, most of whom use pine) Cedar will not warp & curl up over time.
- Tearing down and hauling off of existing wood fence/gates is included (where replacement occurs).
- Houston Fence will call the appropriate representative in order to mark public utility lines upon signing of contract prior to installation.
- Houston Fence crews work exclusively for Houston Fence and are reputable individuals who have all passed comprehensive federal background checks.
- Houston Fence Company is bonded, insured, & protects its employees with Worker's Comp.
- If any access equipment is installed we provide training for use and 24 hour emergency service.
 - We are certified under TX License #B16502 and use ONLY in-house installers for security reasons.
 - Our techs are factory trained and we offer a full line of products and accessories.

Houston Fence Company has been working diligently to earn & fulfill Home & Business owner's fencing, gate, and access control needs in the greater Houston area since 1952. As your sales representative I vow to exceed your expectations and will professionally serve your needs as I am allowed and capable. If there is anything not expressly written in this proposal that needs to be altered, added to, or omitted, please inform me before proceeding into contract stage. Thank you for allowing us the honor of presenting you with this proposal.

“Our reputation is your guarantee.”

A name you can trust

Congratulations! With over 10,000 five-star reviews and a stellar 94% satisfaction rating, we are the most highly rated and reviewed fence company in the country.

We are excited to help you build your new fence! Please find your fence package options below, and simply click on the package to select it.

Kyle Hill

635 Hallie Drive
Houston, TX 77024

PAY FOR YOUR PROJECT WITH:



[CLICK HERE TO GET A CREDIT DECISION IN SECONDS](#)

Select Package



\$568 per month

8ft H Cedar with 2x12 Rot Board, 2x6 PT Cap and 1x4 PT Trim, 4x4 PT Posts (8ft H Total)

8'H Cedar Stockade

Cedar Brown

Features & Benefits

- Premium Grade Treated Posts and Rails
- Premium Grade Cedar Pickets
- Stainless Steel Gate Hardware
- Superior 3-Rail Construction Built from Scratch On-Site

Specifications

- **Post:** 4" x 4"
- **Rail:** 2" x 4"
- **Picket:** 1" x 6"

Warranty

- 3-Year Workmanship Warranty

[Choose this package ↓](#)



\$611 per month

8ft H Cedar w/2x12 PT Rot Board, 2x6 PT Cap and 1x4 PT Trim, and Steel Postmaster Posts (8ft H Total)

8'H Cedar Stockade

Cedar Brown

Features & Benefits

- Premium Grade Treated Posts and Rails
- Premium Grade Cedar Pickets
- Stainless Steel Gate Hardware
- Superior 3-Rail Construction Built from Scratch On-Site

Specifications

- **Post:** 4" x 4"
- **Rail:** 2" x 4"
- **Picket:** 1" x 6"

Warranty

- 3-Year Workmanship Warranty

[Choose this package ↓](#)

The image shown is a representation of the style of the fence, and not meant to be a specification of the height, color, or grade.

Customer has an open pool.

"ABOVE AND BEYOND"

This company was a pleasure to deal with from the time we started our project you could tell that customer service was very important to them. This showed in the way they explained the project to making sure that every deadline was met. I would deal with the company again because they showed great integrity in business.



Judith Volger

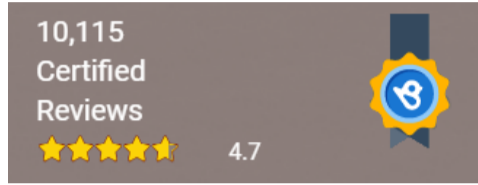

Today's Price: **8ft H Cedar with 2x12 Rot Board, 2x6 PT Cap and 1x4 PT Trim, 4x4 PT Posts (8ft H Total)** **\$39,991.87**

Choose your payment method

Pay with ACH/E-Check
Save **\$599.88**

\$39,391.99

Pay with Credit Card

\$39,991.87

Contact Sales



Griffin Fence



6307 Brittmoore • Houston, Texas 77041-5117

(713) 937-6611 • FAX: (713) 937-6751

HOUSTON'S PREMIER FENCE COMPANY SINCE 1979

INTEGRITY | SERVICE | PROFESSIONALISM

Contact

CUSTOMER Kyle Hill

DATE 7/19/22

HOME # _____

BILLING ADDRESS _____



ZIP _____

CELL # 713 899-3054

PROJECT ADDRESS 635 Hallie Dr, 77024

EMAIL: Kyle@westside

Realtors.com

WOOD FENCE 1"X6" <input checked="" type="checkbox"/> <u>7'</u> <input type="checkbox"/>	ORNAMENTAL IRON		CHAIN LINK	
HT <u>8'</u> WOOD cedar	HEIGHT _____	COLOR _____	HEIGHT _____	TOP RAIL _____ O.D.
BASE-BOARD <u>2x12"</u>	PLUGS _____	SPEARS _____	GAUGE _____	LINE POST _____ O.D.
 Notch Top	PRESSED _____	PICKET _____	RESIDENTIAL <input type="checkbox"/>	END POST _____ O.D.
 With Cap	SPEARS _____	SIZE _____ IN.	COMMERCIAL <input type="checkbox"/>	CORNER POST _____ O.D.
 French Goth	RAIL _____	POST _____ IN.	KNUCKLE UP <input type="checkbox"/>	WALK GATE POST _____ O.D.
<input type="checkbox"/> Other	SIZE _____ IN.	SIZE _____ IN.	TWIST UP <input type="checkbox"/>	DRIVE GATE POST _____ O.D.
	SPACING BETWEEN PICKETS _____ IN.			GATE FRAMES _____ O.D.

INFORMATION

- 720' 8'-tall wood using
- 1x6x7' w.r. cedar
- 2x12" treated pine
- "beveled" baseboard
- 3 treated pine rails
- 4"x4" treated pine posts in 3' concrete spaced 7' apart
- cedar cap + trim

T&H Tear down + haul fence

Above cost = \$35,640

Gate 4'x8' e galv. frame

* Cost = \$375

option → Metal posts 2 3/8" adds \$6262

\$50 SPRINKLER PROTECTION PLAN

PLEASE INITIAL ON LINE INDICATED FOR PROTECTION PLAN

YES NO

NOTE: IF NEITHER LINE IS INITIALED BY CUSTOMER, THEN "NO" IS ASSUMED AND UNDERGROUND PROTECTION PLAN IS NULLIFIED.

CONTRACT IS SUBJECT TO COMPANY APPROVAL.

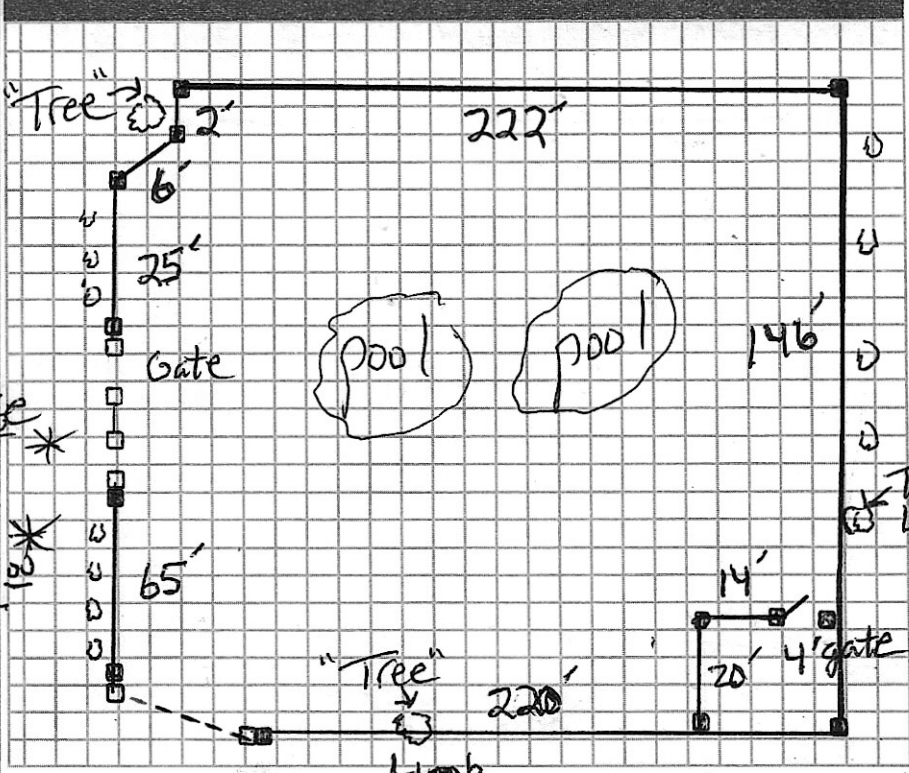

NOTE: Failure to comply with payment within a 5-day period after completion of work will be subject to maximum interest and penalty allowable by law and possible court costs. There will be a 3% charge on all credit card payments.

Project Amount \$ 36,015⁰⁰

Deposit Amount \$ _____

Due on Completion \$ _____

CUSTOMER SIGNATURE

IMPORTANT NOTICE-State law requires all fence contracts to contain the following: You and your contractor are responsible for meeting the terms and conditions of this contract. If you sign this contract and fail to meet the terms and conditions of this contract, you may lose your legal ownership right in your home. KNOW YOUR RIGHT AND DUTIES UNDER THE LAW.

Lee Patton

SALES REPRESENTATIVE

CONTRACT CONDITIONS

ACCEPTANCE-The above proposal when signed by the Customer and accepted by the Company becomes a Contract between the two parties. Cancellation of the Contract by the Customer after Acceptance by the Company and prior to substantial work being completed is subject to a minimum penalty of 50% of the total Contract Amount payable to the Company. The Customer is solely responsible for the following: Locating, Staking, and Clearing Property Lines; Obtaining Building Permits; and Compliance with Deed Restrictions. Your Sales Representative is available to assist where possible. The Company will not be held responsible or liable for any direct or indirect damages related to any unmarked underground lines or obstructions except where required by Applicable Law. If the contract or the Scope of the Project is changed by the Customer, therefore causing a delay to the crew or loss of Work Product in any form to Griffin Fence, then the Customer may be subject to Additional Charges by the Company. Final Payment is due in full at the Completion of the Project unless otherwise noted. The Customer will be held liable for all legal fees, collection fees, and applicable interest if any portion of the Contract amount is not paid according to the terms of the Contract. The Company reserves the right to enter the property and repossess all materials used on the job without recourse. ALL SALES ARE FINAL.

A name you can trust

Congratulations! With over 10,000 five-star reviews and a stellar 94% satisfaction rating, we are the most highly rated and reviewed fence company in the country.

We are excited to help you build your new fence! Please find your fence package options below, and simply click on the package to select it.

Kyle Hill

635 Hallie Drive
Houston, TX 77024

PAY FOR YOUR PROJECT WITH:



[CLICK HERE TO GET A CREDIT DECISION IN SECONDS](#)

Select Package



\$568 per month

8ft H Cedar with 2x12 Rot Board, 2x6 PT Cap and 1x4 PT Trim, 4x4 PT Posts (8ft H Total)

8'H Cedar Stockade

Cedar Brown

Features & Benefits

- Premium Grade Treated Posts and Rails
- Premium Grade Cedar Pickets
- Stainless Steel Gate Hardware
- Superior 3-Rail Construction Built from Scratch On-Site

Specifications

- **Post:** 4" x 4"
- **Rail:** 2" x 4"
- **Picket:** 1" x 6"

Warranty

- 3-Year Workmanship Warranty

Choose this package ↓



\$611 per month

8ft H Cedar w/2x12 PT Rot Board, 2x6 PT Cap and 1x4 PT Trim, and Steel Postmaster Posts (8ft H Total)

8'H Cedar Stockade

Cedar Brown

Features & Benefits

- Premium Grade Treated Posts and Rails
- Premium Grade Cedar Pickets
- Stainless Steel Gate Hardware
- Superior 3-Rail Construction Built from Scratch On-Site

Specifications

- **Post:** 4" x 4"
- **Rail:** 2" x 4"
- **Picket:** 1" x 6"

Warranty

- 3-Year Workmanship Warranty

Choose this package ↓

The image shown is a representation of the style of the fence, and not meant to be a specification of the height, color, or grade.

8ft H Cedar w/2x12 PT Rot Board, 2x6 PT Cap and 1x4 PT Trim, and Steel Postmaster Posts (8ft H Total) - 718 LF

8'H Cedar Stockade

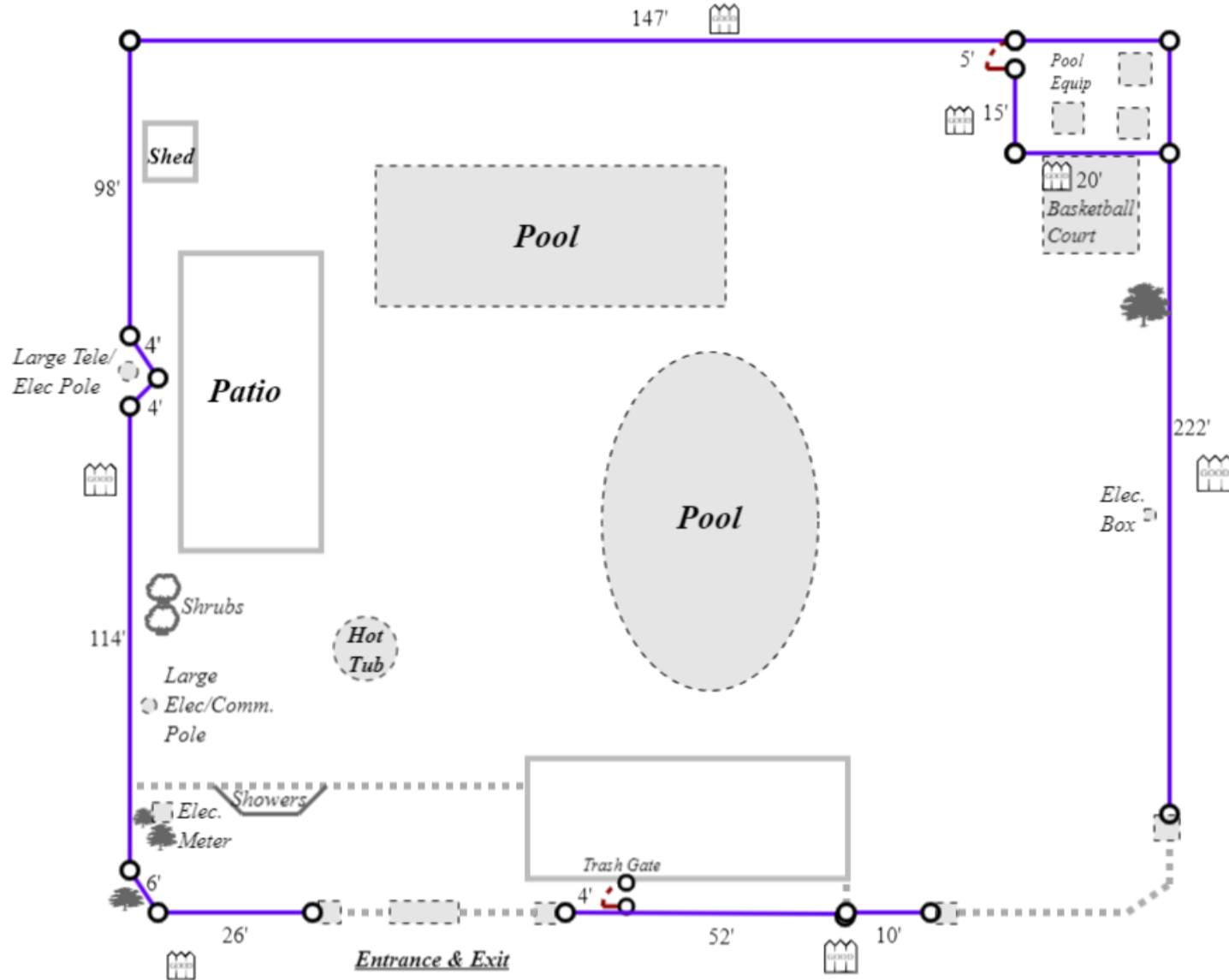

FENCE FOOTAGE CONTAINED IN THIS PROPOSAL IS APPROXIMATE BASED ON THE FIELD MEASUREMENTS, FINAL PRICE WILL BE ADJUSTED BASED ON ACTUAL FOOTAGE USED, AS SET FORTH IN THE TERMS AND CONDITIONS.

Included in the job

1 4' Gate, 1 5' Gate
227 Linear Feet - Wood - PT 2x12 Rot Board
227 Linear Feet - Top Cap 2x6 (per LF)
227 Linear Feet - Wood - 1x4 Trim Add
227 Linear Feet - Take Down and Haul Away
227 Linear Feet - Wood - Upgrade to 11' Postmasters

Job Notes

Client will get an 8ft H (Total) Cedar fence with a 2x12 Beveled PT Rot Board, 2x6 Cap, and 1x4 Trim. Option one will have 4x4 Pressure treated Posts and Option 2 will have Steel Postmaster Posts. Client is required to clear fence line prior to the install date. All of our work includes a 3-year workmanship warranty. If you have any questions or concerns, please contact me @ (832)643-7962 or email me at cody@westhoustonfence.com. We are a company that really emphasizes on communication so don't hesitate to reach out. We look forward to working with you!

Customer to clear fence line.

Customer has an open pool.

"ABOVE AND BEYOND"

This company was a pleasure to deal with from the time we started our project you could tell that customer service was very important to them. This showed in the way they explained the project to making sure that every deadline was met. I would deal with the company again because they showed great integrity in business.



Judith Volger

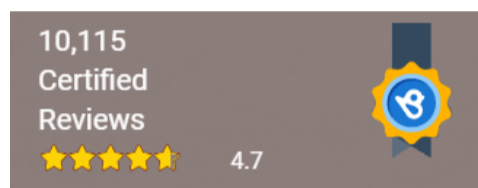

Today's Price: **8ft H Cedar w/2x12 PT Rot Board, 2x6 PT Cap and 1x4 PT Trim, and Steel Postmaster Posts (8ft H Total)** \$42,947.17

Choose your payment method

Pay with ACH/E-Check
Save \$644.21

\$42,302.96

Pay with Credit Card

\$42,947.17

Contact Sales



HOUSTON FENCE COMPANY, INC
Since 1952

11851 ORMANDY ST.
HOUSTON, TEXAS 77035

PHONE (281) 499-2516
FAX (832) 539-1144

PROJECT BID

DATE: August 19, 2022
PROJECT: Cedar Wood Fence
CLIENT: Kyle Hill – 713-899-3054; kyle@westsiderealtors.com
Fonn Village: 635 Hallie Dr. Houston, TX 77024

- FENCE TYPE: Privacy, #2 or better cedar
- LINEAR FOOTAGE: 720 linear feet of fence
- HEIGHT: 8'2" Tall
- PICKETS: 1"x6"x7'
- BASEBOARD: 2"x12" beveled edge treated pine
- CAP & FACE: 2"x6" cedar cap with 1"x2" cedar face
- RAILS: 3 – 2" x4" treated pine rails, toe in nailed
- NAILS: Hot dip galvanized ring shanked nails to be used
- POSTS: 4"x4" Treated posts set 3' deep in concrete on 6' centers
- GATES: (1) 4' & (1) 5' walk gate, both gates include galvanized tubing framework, self-tapping screws on the square frame, powder coated black T-hinges, & a paddle latch accessible from both sides of the fence, but lockable from inside
- TEAR & HAUL: Included

Houston Fence will notify the "One Call" center for locating and **marking all public utilities** on and by the property. Houston Fence Co. is licensed by the State of Texas No.# B16502 and **insured/bonded through by Allied P & C Insurance Company up to \$5,000,000 liability each occurrence.**

Grand Total: \$44,269.04

Please Note: Both availability of product and price in the wood market is extremely volatile at this time. As such, pricing and availability of material will have to be confirmed at time of award to confirm if current prices are up or down and availability.

EXCLUSIONS: Unless noted above. Clearing, grading or locating and marking private underground utilities. Breaking concrete or asphalt to set fence posts, electrical grounding of fence. Permits, bonds, waivers of subrogation and naming of additional insured parties or unless specifically stated above are excluded.

APPROVAL: _____ **DATE:** _____
(Signature)

Grafton Moore, Sales Representative
Houston Fence Co., Inc.
832-525-3038
grafton@houstonfence.com



(P) 281.265.2881 www.houstonfence.com

WHY USE HOUSTON FENCE FOR YOUR WOOD FENCE AND GATE NEEDS

- All of our wooden gates have a galvanized 1-1/4" welded steel frame for support, use patented self-closing hinges, and hang on a hinge post set 4.0' deep in a 240# concrete footing.
 - Pedestrian gates come standard with a powder-coated paddle latch which has a pin lock on the inside & a padlock receiver on the outside.
- All of our fence posts are pressure treated & ground rated to minimize moisture absorption and are set 2' deep underground for 6' tall material, and 3' deep for 7' & 8' tall material, in concrete for long term stability. Deeper footings are available at an additional cost
- All our fences use #2 or better Western red cedar pickets. All materials are milled in North America exclusively (Houston Fence Company uses only the best quality product).
- All our fences use 3 rails and are boarded together with galvanized ring shank nails so they will not back out over time.
- If you elect to use a cap rail for your fence we ONLY use cedar (unlike our competitors, most of whom use pine) Cedar will not warp & curl up over time.
- Tearing down and hauling off of existing wood fence/gates is included (where replacement occurs).
- Houston Fence will call the appropriate representative in order to mark public utility lines upon signing of contract prior to installation.
- Houston Fence crews work exclusively for Houston Fence and are reputable individuals who have all passed comprehensive federal background checks.
- Houston Fence Company is bonded, insured, & protects its employees with Worker's Comp.
- If any access equipment is installed we provide training for use and 24 hour emergency service.
 - We are certified under TX License #B16502 and use ONLY in-house installers for security reasons.
 - Our techs are factory trained and we offer a full line of products and accessories.

Houston Fence Company has been working diligently to earn & fulfill Home & Business owner's fencing, gate, and access control needs in the greater Houston area since 1952. As your sales representative I vow to exceed your expectations and will professionally serve your needs as I am allowed and capable. If there is anything not expressly written in this proposal that needs to be altered, added to, or omitted, please inform me before proceeding into contract stage. Thank you for allowing us the honor of presenting you with this proposal.

“Our reputation is your guarantee.”

Titan Fence Supply

P. O. Box 7177
713 – 868 – 9975

Houston, Texas 77248
Fax 713 – 868 – 9975

PROPOSAL

August 20,2022

Fonn Villas Swim Club
635 Hallie Dr.
Houston, Texas 77024

Attn: Kyle Hill
Ref: Perimeter Wood Fencing & Equipment Enclosure

Perimeter Wood Fencing & Gate

Install approx. 720 lft. of 8' (7' tall fence with 12" rot board) tall cedar fencing. Fence installed using the following materials:

- 4 x 4 treated pine posts
- 2 x 4 treated pine horizontal rails (3)
- 2 x 12 treated pine horizontal rot board
- 1 x 6 x 7' cedar fence pickets
- 2 x 8 treated pine cap
- 1 x 2 cedar horizontal trim board
- 1 – 4' wide walk gate at pool equipment enclosure.

Price also includes removing existing fencing and hauling away to an approved dump site. Also included is any temporary chain link fencing that may be needed to keep pool enclosed while existing fencing is removed and before new fencing is installed.

\$ 41,500.00

Alternate: Add for 2 1/2" od. Sch. 40 hot dipped galvanized steel posts with wood fence adapters to steel posts.

Add \$ 7,250.00

Thank you for the opportunity to quote you on this project. If you have any questions please give me a call.

Mark Drummond